

APPLICATIONS



Boiler



Air conditioner



Air conditioning box



Back-to-wall sanitaryware



Dehumidifier

PUMPING

4.5 m



WARRANTIES & EXTENSIONS pg.11



Reference: EAN
3308815083674
SK6



ORIGINE
FRANCE®
GARANTIE

BVCert. 6045364



Sanicondens® Pro



Flexibility: connections possible with gas and oil boilers (using Sanineutral® or Sanineutral® Mini), floor and wall mounted, refrigerated display cases, air conditioners, air conditioning boxes and dehumidifiers.



Compact design.

Quiet < 45 dB(A).



Easy installation:
Complete installation kit inlet and outlet adaptors, all power cables and alarm.
Alarm pre-connection.

SEMI-TRANSPARENT VIEW



PUMP PERFORMANCE CURVE

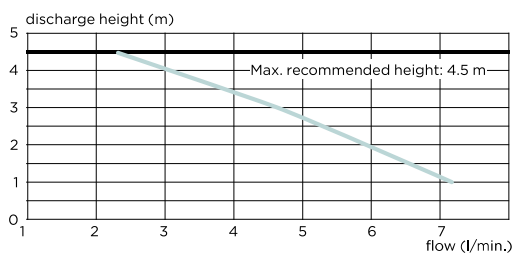

PACKING LIST

Sanicondens® Pro

Check valve supplied

Supplied with: fixing screw, 1 inlet adaptor, 1 outlet adaptor (Ø 50 mm), 1 drainage hose (5 m) and a 1.5 m power cable, 1 rubber cap, 1 alarm pre-connection cable

TECHNICAL FEATURES

Ø of inlets	28 mm
Number of available inlets	2
Ø of discharge pipe	10 mm
Tank volume	2.2 l
Maximum flow at 1 m	6.2 l/min
Maximum temperature of incoming water	80°C (S3 15%)
Max. power of the associated gas boiler	50 kW
Max. power of the associated oil boiler	30 kW
Voltage	220-240 V
Frequency	50 Hz
Max. absorbed power	60 W
Max. absorbed intensity	0.52 A
Electrical class	I
Protection rating (IP)	IP20
Weight	2 kg
Noise level	< 45 dB(A)

Sanicondens[®] Deco ⁺

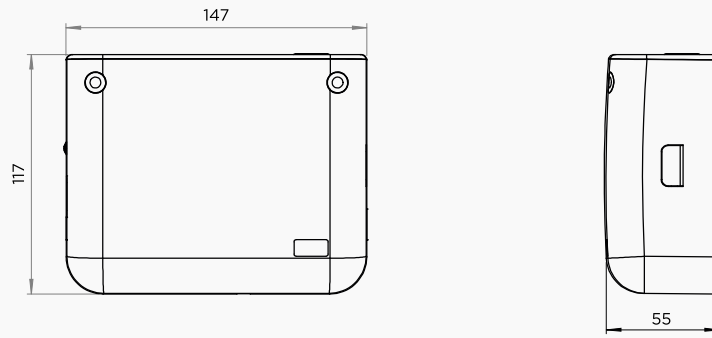

Sanicondens[®] Eco

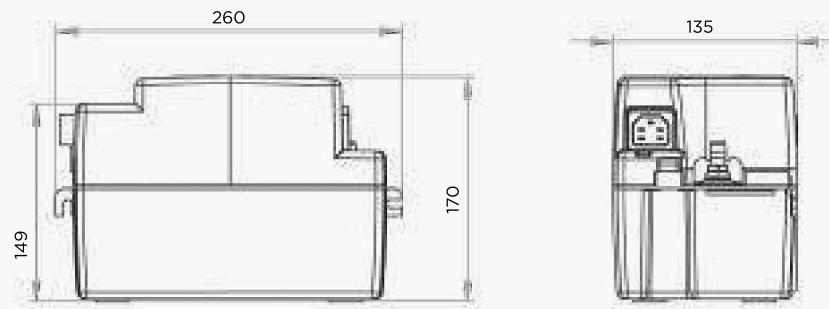

Sanicondens[®] Pro

